

STILL Ergopick. Order picking made easy.



Vacuum handling system for easy and efficient order picking.

Order picking involving heavy loads has always been very challenging work, with operators across all industries often running a high risk of being injured. But that's now a thing of the past now, thanks to STILL Ergopick – allowing you to effortlessly move even heavy loads, while also fulfilling the obligations set out under section 5 of the German Occupational Safety and Health Act regarding general measures to prevent occupational health risks.

The vacuum handling principle has already proven its worth in stationary applications and can now – for the first time ever – be deployed in conjunction with an order picker.

The benefits for you:

- Lift heavy loads without physical exertion
- Back and joints are relieved
- Optimised handling performance
- Integrated system for safe and secure handling
- Handling of different types of goods using a variety of available tools.

STILL Ergopick is an integrated solution with a vacuum gripping system used in conjunction with the STILL CX-S. A vacuum sucker allows operators to easily lift suitably packaged loads of up to 40 kg with minimal effort, while the articulated arm means that loads can be lifted on both sides. In particular with regard to porous materials, we recommend carrying out a test on the material to ensure suitability.

Versatile: STILL Ergopick





Logistics/distribution



Chemicals/food industry



Metalworking/mechanical engineering



Ergopick performance data:

Maximum load	kg	40
Minimum lift (depending on gripper)	mm	1,400
Pump output	W	2,000
Engine output	kW	2.0
Lifting speed	m/s	0.5
Operating range		270°
Overall height h1	mm	2,750
Overall length l	mm	3,852
Travel speed	km/h	9.0
Travel speed > 300 mm h3	km/h	2.8
Battery voltage/nominal capacity	V/Ah	24/620

CX-S 16 with Ergopick

Low level order picker, scissor lift

Articulated arm and maximum grip radius: 2,100 mm

Maximum load capacity: 40 kg

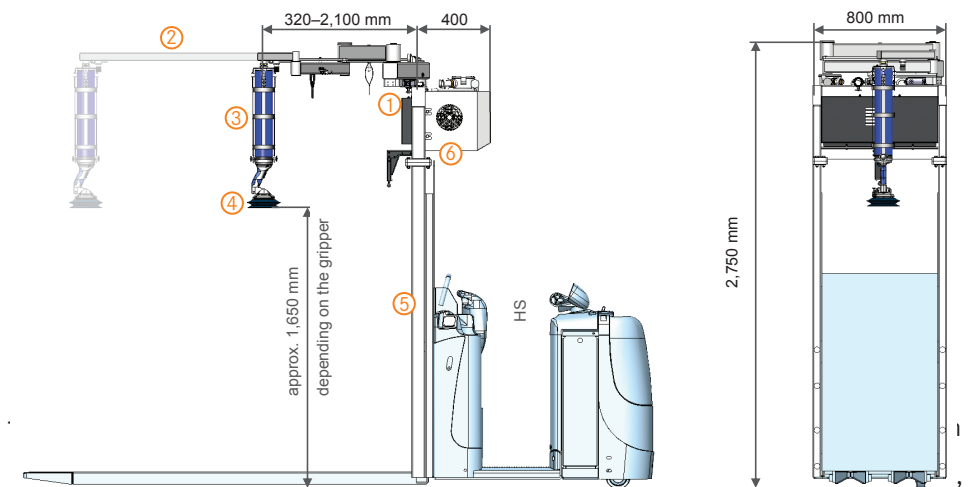
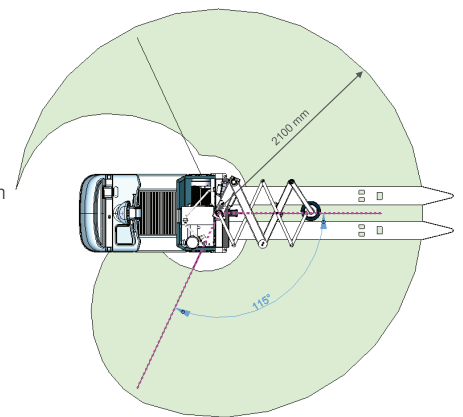

no movement is possible.

- 2) Articulated arm.** The articulated arm allows loads to be smoothly moved horizontally.
- 3) Suction tube.** The suction tube allows loads to be delicately and dynamically moved vertically.
- 4) Vacuum sucker.** The vacuum sucker is used to pick up and hold loads with different levels of porosity. Also available: special tools for different industry requirements.
- 5) Reinforced frame construction.** The reinforced frame construction helps to stabilise the components.
- 6) Vacuum pump.** A quiet pump with powerful suction, with power supplied from the order picker's traction battery.

STILL GmbH

Berzeliusstraße 10

22113 Hamburg, Germany

Telephone: +49 (0)40/73 39-20 00

Fax: +49 (0)40/73 39-20 01

ergopick@still.de

www.still.de

first in intralogistics